

Pre-made Pouch Filler / Sealer TT-8D-N

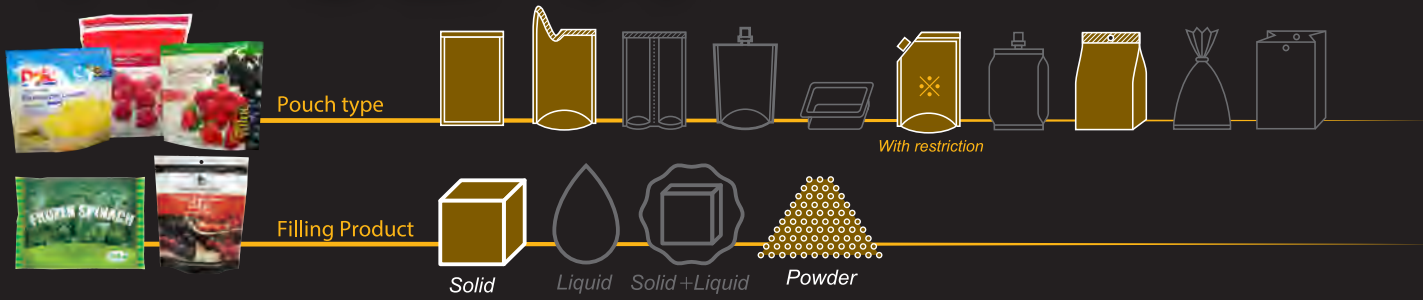

- Widely flexible for various pouch formats and product types.
- Designed for safe and sanitary operation.
- Easy cleaning, washdown design.
- Simple, intuitive operation and maintenance using touch screen controls.
- Optional zipper opening, nitrogen gas flush, liquid filling systems and other features.

Wet Use Stations Simplex





Elevator Magazine

Simplified, cost-effective pouch magazine for flat pouch only applications.



Conveyor Magazine

Flat, standup & floating gusset pouch styles. Optional ptc zipper / corner spout styles. Standard & high capacity versions.



HMI: Color Touch Screens

User-friendly, information rich screens with maintenance functions.

Machine Dimensions

* Specifications & dimensions subject to change without notice

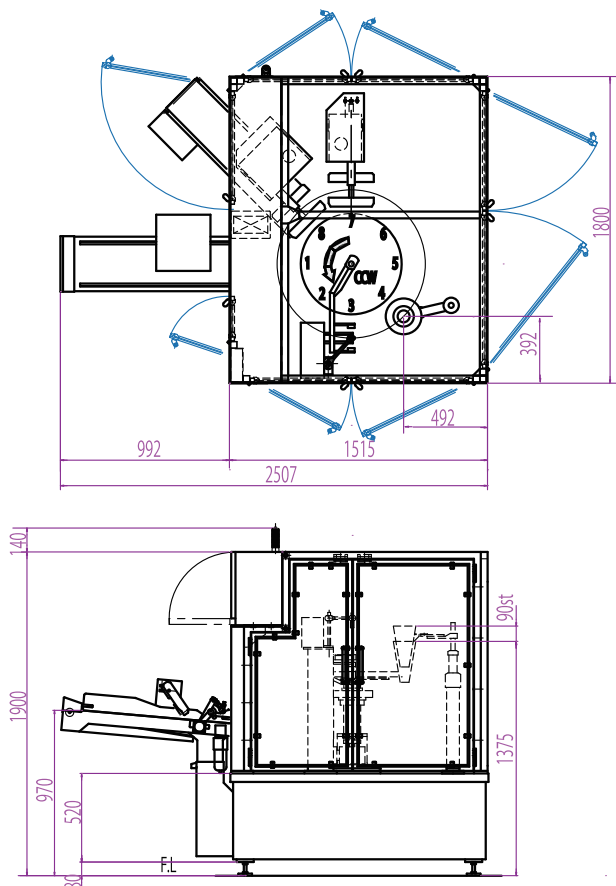

Machine Specifications

* Depending on product

Capacity	max. 55 ppm
Pouch Size	W: 120 - 260 mm, 80 - 220 mm L: 130 - 400 mm
Pouch Material	Various laminated pouches, PE pouch
Pouch Style	Flat, standup & floating gusset. Optional ptc zipper style.
Sealing Method	2-stage heat/cool sealing method
Electric Power	5.7 kVA
Air Consumption	0.5MPa (72psi), 350 - 450NL/min(ANR)
Machine Dimension & Weight	W 1,800 x L 2,507 x H 2,040 mm 1,700Kg
Accessories	Product feeding hopper, Product discharge conveyor Pouch opening following guide, Product counter, Heater disconnection alarm Pouch opening detection device
Options	Date printer, Air squeeze device, Tapping Stand-up pouch bottom opening device N2 Gas flush device, Zip open-close device Fill pause mode, Seal area cleaning, Pouch recycle, Double pouch detection, Various filling devices, Pouch pick-up position detection, Product in seal detection

Applications

Frozen foods, Seafood, Snacks, Rice & other grains, Noodles, Pet foods, Granular & powder products and many others