

# High Speed Pre-made Pouch Filler / Sealer TT-10CWS

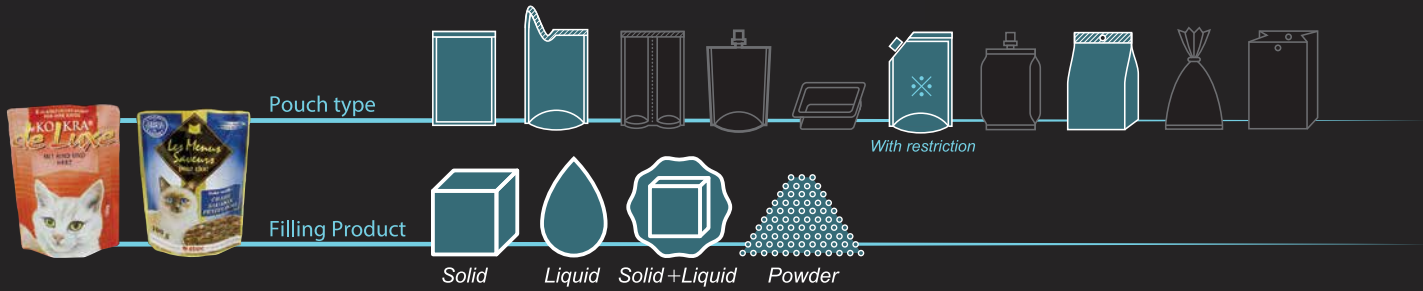

- Small pouch filler / sealer offering 1.5 x speed when compared with our popular TT-9CW.
- Duplex filler sealer for use with one or two-stage filling applications.
- Dramatic cost reduction in high capacity, small pouch retort & hotfill applications.
- Highly efficient & durable construction for multi-shift operation & long operating life.



Retort/Hotfill



Wet Use



10 Stations



Duplex



## Machine Specifications

Capacity	max. 125 ppm (With Cup Filler : 100 ppm)	
Pouch Size	W: 70 - 100 mm	L: 120 - 170 mm
Pouch Material	Various laminated pouches, PE pouch	
Pouch Style	Flat, Stand-up and pouches with press-to-close	
Filling Method	Various pump depending on filling product	
Liquid Filling Volume	50 - 100 cc (STD)	max.200cc
Air Evacuation	Press Type	
Sealing Method	3-stage heat/heat/cool sealing method	
Electric Power	14 KVA	
Air Consumption	0.6 MPa, 1,000 L/min (ANR)	
Machine Dimension & Weight	W 3,380 x L 2,360 x H 1,960 mm	4,700Kg

\* Depending on product

Accessories	Product feeding hopper, Product discharge conveyor Pouch opening follow-up guide, Product counter, Heater disconnection alarm Pouch opening detection device
Options	Date printer, Air squeeze device, Tapping Stand-up pouch bottom opening device N2 Gas flush device, Zip open-close device Fill pause mode, Seal area cleaning, Pouch recycle Double pouch detection, Various filling device, Pouch pick-up position detection, Product in seal detection

## Applications

Pet food, Shelf stable food, Juice, etc.

## Machine Dimensions

\* Specifications & dimensions subject to change without notice.

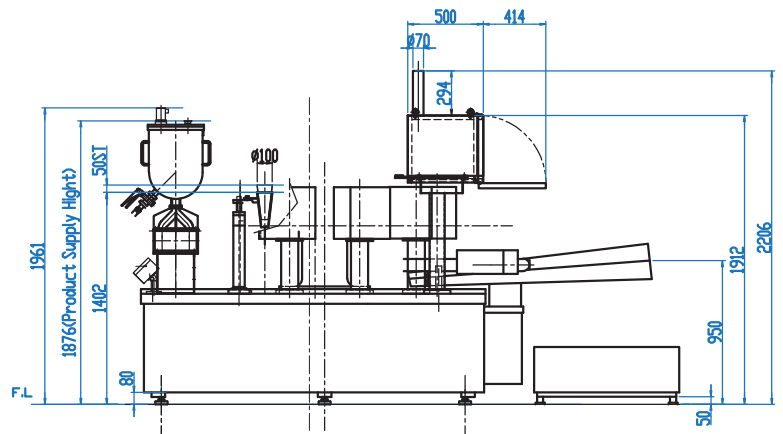
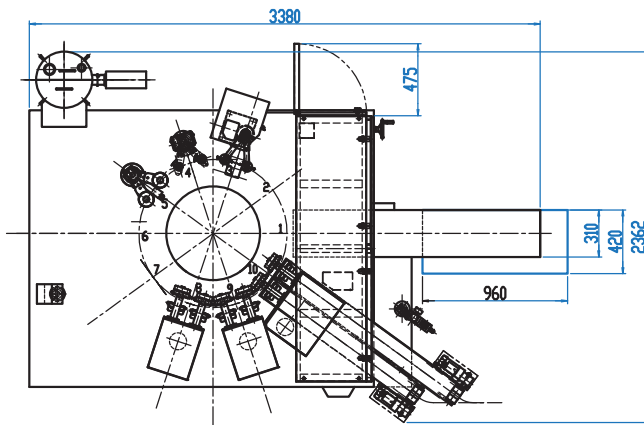

TT-10CWS+CF-90W

